

S1930E

SLAB SCISSOR LIFTS



- Self-propelled electric micro scissor lifts
- Compact and nimble
- Drives through a standard doorway
- 0.81m wide model rated for outdoor use
- Easy to use and maintain

 **snorkel**
www.snorkellifts.com

SLAB SCISSOR LIFTS

S1930E

DIMENSIONS	S1930E
Max. working height	7.6m
Max. platform height (A)	5.6m
Platform size (stowed)	0.64m x 1.56m
Platform size (extended)	0.64m x 2.44m
Deck extension length	0.88m
Overall width (D)	0.76m
Overall length (C)	1.85m
Stowed height (B)	1.97m
Wheelbase	1.37m
Ground clearance (stowed)	63mm
Ground clearance (elevated)	19mm

PERFORMANCE	
Platform capacity (SWL)	227kg
Max. operating wind speed (1 person on platform)	12.5m/s
Max. drive height	5.6m
Max. drive speed (stowed)	3.2km/h
Max. drive speed (elevated)	0.6km/h
Raise/lower time	20/26 seconds
Gradeability	25%
Inside turning radius	0.13m
Outside turning radius	1.64m
Tyres	305mm x 102mm non-marking solid rubber
Controls	proportional
Drive system	2 wheel hydraulic

POWER	
Power source	4 x 6V 220 amp hour batteries
Charger	90 - 240V, 25 amp

WEIGHT	
Gross weight	1,525kg

TURNING RADIUS

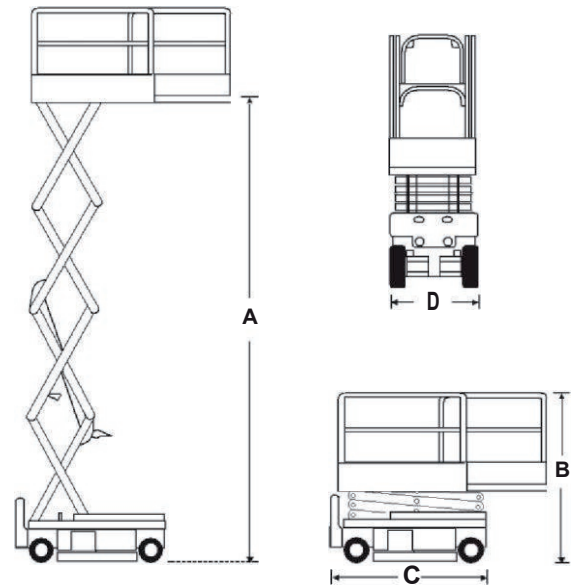
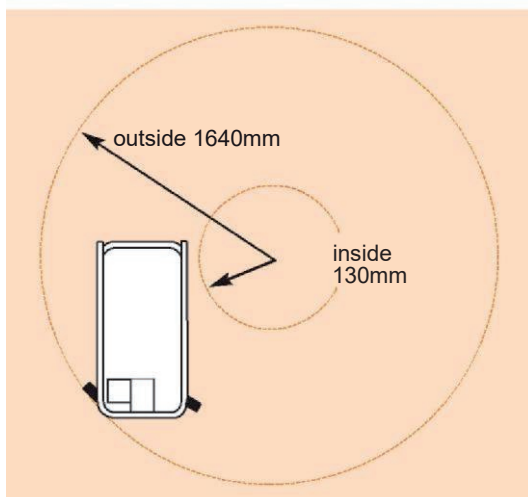

STANDARD FEATURES

- Pothole protection system
- Non-marking tyres
- Proportional controls
- 0.8m extension deck
- Approved for outdoor use with one person on platform
- Swing -out service trays
- Horn
- Hour meter
- Level sensor with drive/lift interlock
- CE approved
- Flashing amber beacon

OPTIONS

- Special paint colours
- Power to platform
- Dual lanyard anchorage point
- Mine specification
- Flame proofing

snorkel www.snorkellifts.com

2/26 Redfern Street,
Wetherill Park,
NSW 2164, Australia
t: +61 1300 900 700
e: sales.au@snorkellifts.com