

Vertical Mast

Snorkel



- 5.7m max. working height
- Ultra-compact design
- Drives through standard doorway or narrow aisles
- 227kg platform capacity
- Transportable in most passenger elevators
- Non-marking tyres
- Step-on / step-off platform

TM12

TM12 vertical mast specifications

TM12 VERTICAL MAST

max. working height A	5.7m
max. platform height B	3.7m
max. drive height	3.7m
platform capacity (SWL)	227kg
platform size (inside)	0.74m x 1.04m
width C	0.76m
stowed height D	1.7m
stowed length E	1.36m
gross weight	776kg
drive speed - max.	3.65km/h
with platform raised	1.0km/h
gradeability	14°/25%
inside turning radius	0.37m
ground clearance	76mm
lift speed - raise/lower	18 seconds/25 seconds
drive system	dual front hydraulic motors
tyres	305mm dia. solid rubber, non-marking
battery charger	90V - 240V - 25 amp automatic
parking brake	2 wheel, spring-applied, hydraulically-released with manual overdrive
control system	one-hand proportional controls
power source	24V 4hp DC electric motor 4-220 Ah batteries

DANGER: Models described in this brochure are NON-INSULATED and do not provide electrocution protection from contact with or close proximity to energized conductors which is pointed out on decals and placards attached to the machine. Only qualified and trained operators are to be authorized to use and operate a work platform. Aerial work platforms must be elevated only on firm, level surface. This literature is for illustrative purposes only. Consult Operating Maintenance and Parts Manuals for proper procedures. Specifications may vary and are subject to change without notice or obligation.

The Snorkel TM12 provides a safe, efficient means of working at height in restricted spaces typically encountered in offices, retail stores, hotels, public buildings or crowded industrial aisles. Its compact size also makes it ideal for applications such as stock picking and record storage retrieval. Operators simply step onto the platform, drive to the work location and elevate to the desired height. When the job is complete, the lift can be quickly lowered and returned to a convenient storage area.



BP1, TM12 AUS 11/07

standard features

- Proportional controls
- Drives at full height
- 24V DC 4hp electric motor provides clean, pollution-free power for indoor use
- Descent and tilt alarms
- High amp hour rating gives long usage between charges
- 25 amp charger for easy overnight re-charging
- Emergency lowering at chassis controls
- Non-marking, solid rubber tires
- D-ring tie down points
- Selectable motion alarm
- 1 year parts and labor warranty
- 5 years structural warranty

options

- Overload alarm
- Special paint colors
- Environmental green oil

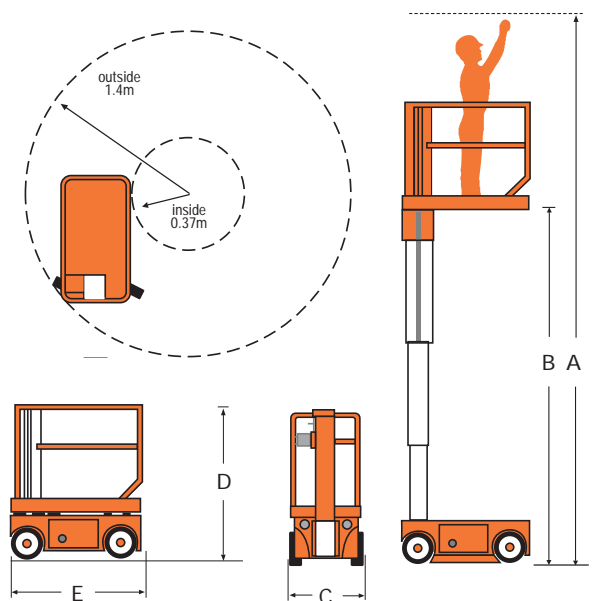

Meets or exceeds applicable requirements of OSHA, ANSI A92.6 and CSA B354.1-04



This product is available with the CE mark confirming compliance with all relevant European Machinery Directives

manufactured by
Snorkel
INTERNATIONAL

Snorkel

Australia 2/26 Redfern Street Wetherill Park NSW 2164

Tel: +61 2 9725 4000 Fax: +61 2 9609 3057

New Zealand 36 Bruce Road Levin

Tel: +64 6 3689 168 Fax: +64 6 3689 164

www.snorkel.com.au